

# Noise Power Ratio (NPR) Testing of HF Receivers

- *Using notched noise to evaluate dynamic receiver performance*

by Adam Farson, VA7OJ/AB4OJ

## A. Introduction.

Noise-power ratio (NPR) testing is a performance test technique in which a notched noise-band is applied to the input of the DUT, and the output of the DUT is connected to a selective level meter whose bandwidth is less than that of the notch in the noise spectrum. The ICN (idle-channel noise) is measured with the noise-band (1) not notched and (2) notched.

The theory behind the NPR test is that the incident noise outside the notch will cause reciprocal mixing noise and multiple IMD products, which will appear in the idle channel (the passband of the selective level meter) and raise the ICN (idle-channel noise). This test method is used in characterising multi-channel FDM/FM systems (terrestrial microwave and satcom), where a notched noise-band of equal bandwidth to the baseband is applied at the transmit end, and a receiver with a channel filter as wide as (or narrower than) the notch is used to measure ICN with and without the notch inserted in the noise-band.

When testing an HF receiver, the receiver itself serves as the selective level meter. The test requires the IF bandwidth to be no wider than the bottom of the notch; the IF filter must not be wide enough to allow noise outside the notch to spill over into the IF. A bandpass filter following the noise generator determines the total noise-band width. In the W&G RS-50 used here, the 60...5600 kHz bandpass filter (band-limiting filter) is selected (**Fig.3**).

## B. Derivation of NPR; noise-bandwidth considerations.

NPR for a given noise bandwidth (or equivalent number of channels) is the ratio of the noise power in the notched band to the power in an equal bandwidth adjacent to the notch.

I2VGO has shown (**Ref. 4**) that for a given noise bandwidth, and at the optimum noise-loading point (see **D** below),

$$\text{NPR} = P_{\text{TOT}} - \text{BWR} - \text{MDS} \quad (1)$$

where  $P_{\text{TOT}}$  = total noise power in dBm in the noise bandwidth  $B_{\text{RF}}$   
 $\text{BWR} = 10 \log_{10} (B_{\text{RF}}/B_{\text{IF}})$   
 $B_{\text{RF}}$  = RF bandwidth or noise bandwidth in Hz (RS-50 band-limiting filter)  
 $B_{\text{IF}}$  = receiver IF filter bandwidth in Hz  
 $\text{MDS}$  = minimum discernible signal (specified at  $B_{\text{IF}}$ )

There has been some discussion as to whether  $B_{\text{RF}}$  should be taken as the total bandwidth of the noise source (i.e. that of the band-limiting filter) or that of the receiver's RF bandpass filter/preselector. It is suggested here that we should use the total noise-source bandwidth as the  $B_{\text{RF}}$  term, because determination of the receiver's RF filter bandwidth is an inexact science at best. As will be seen from **Fig.1**, flattening of this filter's response curve due to blow-by and passive IMD in filter components suggests at a first approximation that neglecting its effect on BWR will not cause a significant error in the  $B_{\text{RF}}$  term.

In practice, if we can assume that  $B_{\text{RF}}$  is determined by the band-limiting filter in the noise generator, NPR testing of multiple receivers will be greatly simplified at the cost of a fairly small measurement error. It can also be argued that the NPR test subjects all stages of the receiver to noise loading, including any front-end filter or preselector, and that therefore any effects which the incident noise generates in the front-end filter should be taken into account in the NPR measurement. To put the impact of the NPR test into perspective, a -9 dBm  $P_{\text{TOT}}$  level at 5.6 MHz  $B_{\text{RF}}$  is equivalent to **1200 simultaneous SSB signals at -43 dBm each, i.e. S9 + 30 dB!**

**Fig.1: Band-limiting filter response, showing secondary effects.**

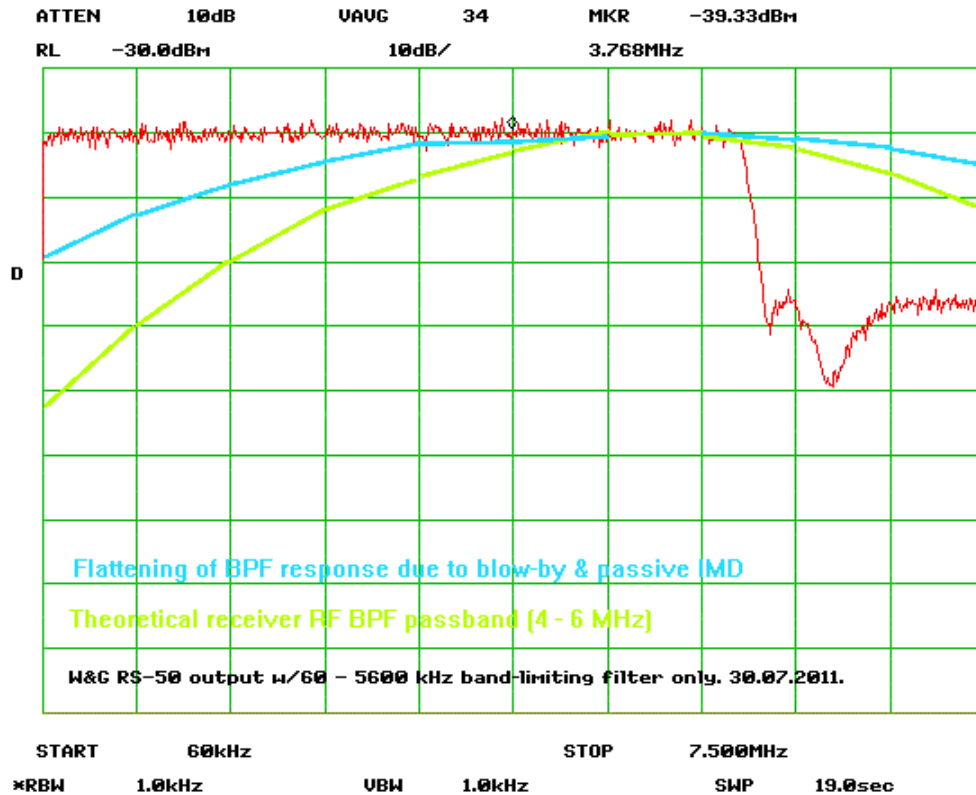

**C. Notch (bandstop) filter design considerations:**

1. The stopband width (notch width) at maximum attenuation must be greater than the IF bandwidth at which the receiver will be tested. It should also be wide enough to allow for any possible frequency drift in the filter.
2. The attenuation required in the stopband must be sufficient to prevent any direct transfer of noise to the receiver under test at its tuned frequency. Thus, if  $D_{TOT}$  is power spectral density (PSD) of the applied noise-band in dBm/Hz,  $B_n$  is stopband width in Hz and  $A_n$  is stopband attenuation in dB, and MDS is the receiver's minimum discernible signal in dBm, the measuring system must satisfy Equation 2.

$$(D_{TOT} + 10 \log_{10} B_n) - A_n \leq \text{MDS} \quad (2)$$

Ref. 7 gives a correction factor which should be applied if the measured NPR is close to the notch depth of the bandstop filter.

$$\text{NPR} = 10 \log_{10} \{10^{-(\text{NPR}_m / 10)} - 10^{-(A_n / 10)}\} \quad (3)$$

where  $\text{NPR}_m$  is the measured NPR and  $A_n$  is the stopband attenuation of the bandstop filter.

**D. Determination of optimum noise loading:**

Ref. 3, Section 7.1, describes the NPR curve of a typical multi-channel transmission system as a function of noise loading. At low incident noise power levels, thermal noise is dominant, and NPR is roughly proportional to noise loading, where an increase of 1 dB increases NPR by  $\approx 1$  dB. This curve is also presented in Fig.2, and in Ref. 4, Slide 28.

**Fig.2: Optimum NPR as a function of noise loading.**

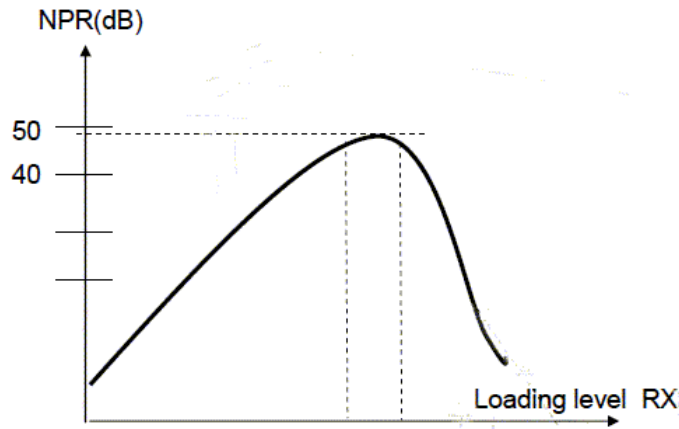

As the noise loading level is further increased, the NPR increase is less than that in input power due to the effect of intermodulation (IMD) products. At a certain noise-loading level, IMD products begin to predominate over thermal noise and NPR starts to decrease. The turnover point is the “optimum noise loading level”, at which the receiver’s NPR will be measured. Per **Ref. 4**, the optimum noise loading level is determined for each test case by increasing noise loading until ICN (idle-channel noise) is **3 dB** above the level when the noise generator is switched off (ICN at MDS). This greatly simplifies the measurement of NPR on receivers.

The NPR falls off rapidly at very high noise-loading levels. The slope on the right-hand side of the curve (noise loading > optimum value) is steeper since the IMD products are dominant in this case.

Any direct transfer of noise due to the limited stopband attenuation of the notch filter will add to the IMD noise, thus reducing the optimum noise loading value. This effect will be negligible if the notch depth satisfies Equation (2) above (as is the case for the W&G RS-50).

### E. NPR test instrumentation.

The author was fortunate enough to locate a Wandel & Goltermann RS-50 White Noise Generator on the surplus test-equipment market. This generator, together with its companion RE-50 noise receiver, forms the RK-50 NPR test system used for many years in the telecommunications industry. The RS-50 is illustrated in **Fig. 6**.

The RS-50 generates a 6 kHz...12.5 MHz noise-band. Its output level is adjustable from -51 to +15 dBm. The instrument is fitted with 3 band-limiting filters and 6 bandstop filters covering CCITT (ITU-T) standard FDM baseband widths and test channel frequencies. For our purposes, the 5340 kHz filter is most suitable; its stopband width and attenuation are 3.3 kHz and  $\approx 97$  dB respectively. The RS-50 incorporates a precision attenuator (1 and 0.1 dB steps) and an ALC loop which holds the output constant at any level setting, irrespective of which filters are selected. **Fig. 3** illustrates the test setup for NPR testing of an HF receiver.

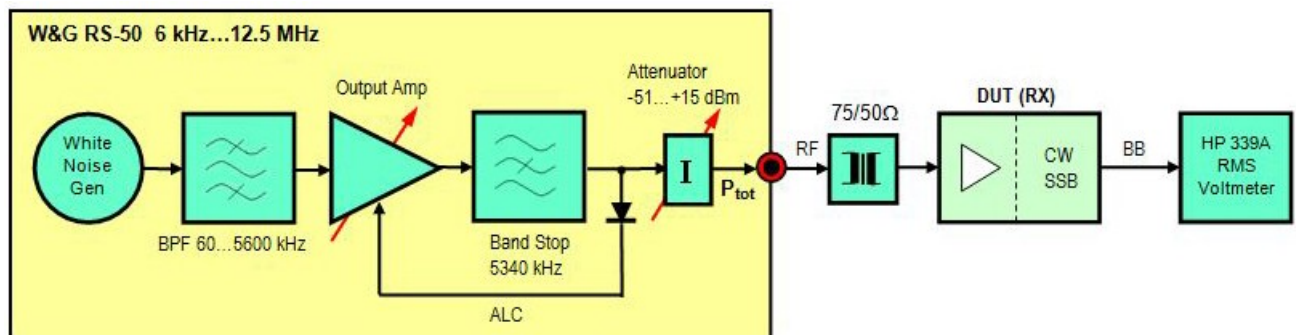

**Fig.3: Noise Power Ratio (NPR) Measuring Setup**

## F. NPR test procedure (conventional receivers):

1. Set RX IF bandwidth/mode to 2.4 kHz SSB. Select SHARP shape factor (if applicable) *The IF bandwidth should be narrower than the stopband width of the notch filter.* Noise Blanker (NB), Noise Reduction (NR), Attenuator (ATT) and Preamp are all OFF. RF GAIN is at maximum. Select 6 kHz roofing filter (if applicable), and set AGC to MID. Tune DUT such that the IF passband is centred in the notch. If the DUT has a switchable preselector, this should be ON initially.
2. On RS-50, set RF attenuator to minimum (-50 dBm). Press and hold GENERATOR BLOCKING key and adjust receiver AF GAIN for 0 dBr reading on the RMS voltmeter connected to the baseband (audio) output.
3. On RS-50, release GENERATOR BLOCKING key. Adjust attenuator for a +3 dBr reading on RMS voltmeter. Record attenuator setting: this is  $P_{TOT}$  (total noise power).
4. Calculate NPR using Equation 1 (refer to **B.** above):

$$NPR = P_{TOT} - BWR - MDS$$

5. Repeat test with different combinations of preselector, roofing filter and preamp, and record results. Take each reading 2 – 3 times and average for highest accuracy.

## G. NPR test procedure (direct-sampling SDR receivers):

When testing NPR on a direct-sampling SDR receiver, the noise loading level required to raise ICN by 3 dB may exceed the clipping (0 dBFS) point of the receiver's ADC. Thus, it is more convenient to increase the noise loading until the onset of clipping is reached, then back off the noise level until no clipping alarm occurs for at least 10 seconds (Ref.4, Slide 36.) NPR can then be read directly off the spectrum scope display or the signal-strength meter.

### Test steps:

1. Set RX IF bandwidth/mode to 2.4 kHz SSB. Select SHARP shape factor (if applicable) *The IF bandwidth should be narrower than the stopband width of the notch filter.* Noise Blanker (NB), Noise Reduction (NR), Attenuator (ATT), Dither and Preamp are all OFF. RF GAIN is at maximum. Select 6 kHz roofing filter (if applicable), and set AGC to SLOW. Tune DUT such that the IF passband is centred in the notch. If the DUT has a switchable preselector, this should be ON initially.
2. On RS-50, set RF attenuator to minimum (-50 dBm). Press and hold GENERATOR BLOCKING key and read MDS from DUT's signal-strength indicator or bottom of notch on spectrum display. Averaging should be ON, at mid-range. Record signal-strength reading (in dBm).
3. On RS-50, release GENERATOR BLOCKING key. Adjust attenuator until ADC just clips, then back off until no clipping is observed over  $\approx 10$  sec. Record attenuator setting: this is  $P_{TOT}$  (total noise power).
4. Now tune DUT to a frequency well outside the notch and read noise power on signal-strength indicator. Record signal-strength reading (in dBm).
5. NPR equals the difference between the signal-strength readings taken in steps 4 and 3.
6. Repeat test with different combinations of preselector, dither and preamp, and record results. Take each reading 2 – 3 times and average for highest accuracy.
7. NPR can also be read off the spectrum display by positioning the marker well outside the notch and in the centre of the stopband. NPR is the difference between these two readings. (Refer to **Fig. 4.**)

**Fig.4. NPR spectrogram on Perseus spectrum scope.**

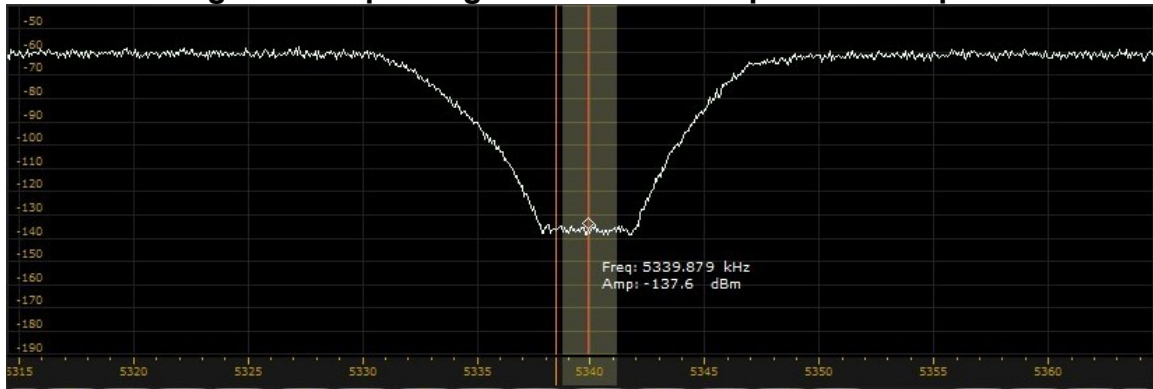

#### **H. Measurement results (with 60...5600 kHz band-limiting & 5340 kHz bandstop filters)**

**Tables 1, 1a** and **2** present the NPR test results for the radios tested with the W&G RS-50.  $B_{RF} = 5.537$  MHz, BWR = 33.6 dB (except where noted), 1200 equivalent voice channels.

The Kenwood TS-590S was tested with the 60...5600 kHz band-limiting and 5340 kHz bandstop filters to select the **High** 1<sup>st</sup> IF (73.095 MHz), and also with the 60...4100 kHz band-limiting and 3886 kHz bandstop filters to select the **Inband** 1st IF (11.374 MHz). For the latter filters,  $B_{RF} = 4.037$  MHz, BWR = 32.3 dB, 960 equivalent voice channels.

MDS is specified at 2.4 kHz IF bandwidth, except where noted (SSB mode).

Since first publication of this article, the author has acquired the following additional W&G filter sets:

1. 60...1296 kHz band-limiting with 70, 240, 534 & 1248 kHz bandstop
2. 60...2044 kHz band-limiting & 1940 kHz bandstop
3. 60...2600 kHz band-limiting & 2438 kHz bandstop
4. 60...4100 kHz band-limiting & 3886 kHz bandstop
5. 316...8160 kHz band-limiting & 7600 kHz bandstop

These filters permit testing on additional bands. As receivers and transceivers are tested on multiple bands, test data sheets will be posted on the website and linked from the Test & Measurement page:

<http://www.ab4oj.com/test/main.html#NPR>

**Table 1: NPR Test Results, Analogue/DSP Radios**

DUT	Config	MDS dBm	P <sub>TOT</sub> dBm	BWR dB	NPR dB
IC-7700	Preamp off R15	-124	-11.6	33.6	78.5
	R6		-4.8		85.3
	R3		-4.9		85.1
	Preamp 1 R15	-138	-24.6		79.5
	R6		-14.8		89.3
	R3		-14.8		89.3
	Preamp 2 R15	-142	-29.7		78.4
	R6		-22.4		85.7
	R3		-22.5		85.6
	Digisel R15	-123	-11.8		77.4
	R6		-4.0		85.0
	R3		-4.2		84.9
TS-590S Inband	Preamp Off	-125	-10.8	32.3	81.6
	Preamp On	-133	-19.5		81.0
TS-590S High	Preamp Off	-126	-16	33.6	76
	Preamp On	-134	-25.5		74.1
K3 #1	<b>K3 #1: 2.7 kHz 5-pole roofing filter fitted</b>				
	Preamp off	-124	-9.7	33.6	80.4
	Preamp on	-128	-14.0		80
K3 #2	<b>K3 #2: 2.8 kHz 8-pole roofing filter fitted</b>				
	Preamp off	-124	-11.7	33.6	78.4
	Preamp on	-129	-15.7		79.4
IC-7600	Preamp off R15	-127	-14	33.6	79
	R6		-12		81
	R3		-12		81
	Preamp 1 R15	-135	-25		77
	R6		-22		79
	R3		-22		79
	Preamp 2 R15	-137	-27		76
	R6		-25		78
	R3		-26		77
IC-7410	Preamp off R15	-129	-18	33.6	77.4
	R6		-18.3		77.1
	R3		-17		78.4
	Preamp 1 R15	-136	-26.1		76.3
	R6		-26		76.4
	R3		-22.4		80
	Preamp 2 R15	-139	-28.1		77.3
	R6		-29.6		75.8
	R3		-27.5		77.9
IC-9100	Preamp off R15	-129	-17.8	33.6	77.6
	R6		-17.8		77.6
	R3		-17.7		77.7
	Preamp 1 R15	-137	-26.3		77.1
	R6		-25.9		77.5
	R3		-25.4		78
	Preamp 2 R15	-137	-27.8		75.6
	R6		-26.6		76.8
	R3		-25.9		77.5

**Table 1a: NPR Test Results, Analogue/DSP Radios (cont.)**

DUT	Config	MDS dBm	P <sub>TOT</sub> dBm	BWR dB	NPR dB
FT-950	IPO R15	-119	-11	33.6	74
	R6		-11		74
	R3		-9.2		76
	AMP1 R15	-130	-21.4		74.7
	R6		-19		77
	R3		-18.4		77.7
	AMP2 R15	-138	--28.4		75.7
	R6		-27.4		76.7
	R3		-26.8		77.3
IC-7200	Preamp off	-124	-18	33.6	72.1
	Preamp on	-135	-28		73.1
FTDX-3000	Preamp off	-125	-12.7	33.6 <sup>1</sup>	72.4
	Preamp 1	-137	-27.3		69.8
	Preamp 2	-140	-30.5		66.6
FT-897D	Preamp off	-124	-18.7	34.0	71
	Preamp on	-131	-31.7		65
IC-703	Preamp off	-125	-21.8	33.6	69.6
	Preamp on	-134	-30.4		70
	Preamp off ATU in	-125	-21.8		69.6
IC-706	Preamp off 2.4 kHz	-132	-31.1	33.6	67.4
	Preamp on 2.4 kHz	-138	-37.3		67.1
	Preamp off 1.8 kHz	-132	-30.9	34.9	66.2
	Preamp on 1.8 kHz	-138	-37.3		65.8
IC-7000	Preamp off	-125	-24	33.6	67.0
	Preamp on	-135	-37		64.3
FT-817	Preamp off	-125	-26.6	33.6	64.5
	Preamp on	-130	-33.5		62.6

**Notes:** 1. 3 kHz 1<sup>st</sup>-IF roofing filter selected.

**Table 2: NPR Test Results, Software Defined Radios (SDR)**

DUT	SW Ver.	Presel	Preamp	Dither	MDS dBm	Clip dBm	P <sub>TOT</sub> dBm	NPR dB <sup>1</sup>
Perseus	4.0b	0	0	0	-122	-3.6	-16.5	72
		0	0	1	-120	-3.6	-19.4	70
		0	1	0	-124	-7.1	-19.9	69
		0	1	1	-120	-7.1	-19.5	68
		1	0	0	-121	-1.5	-8.5	75
		1	0	1	-120	-1.5	-8.8	73
		1	1	0	-123	-5.0	-12.2	73
		1	1	1	-121	-5.0	-12.9	72
KX3	FW Ver.	BB Flt	Preamp		MDS dBm	BWR dB	P <sub>TOT</sub> dBm	NPR dB <sup>2</sup>
	1.10	0	0		-117	32.8	-11.5	72.4
		1	0		-116	33.7	-8.5	73.5
		0	1		-131	32.8	-25	72.9
		1	1		-130	33.7	-21.3	74.7

**Notes:** 1. NPR value measured by observation (see G. above.)

2. NPR calculated from P<sub>TOT</sub> and BWR (see F. above.)

## J. Notes on the theoretical maximum NPR of an ADC:

**Ref. 8**, Figure 2, p.3 gives the theoretical maximum NPR value of **74.01 dB** for a 14-bit ADC. This value can be derived at the optimum noise loading point where  $B_{RF} = f_S/2$ , where  $f_S$  is the sampling frequency of the ADC, and assuming a perfect, noiseless ADC whose noise floor  $N_0$  is:

$$N_0 = (6 * \text{no. of bits}) + 1.76 = 10 \log_{10}(6 * 14) + 1.76 = \mathbf{85.6 \text{ dBFS}} \quad (4)$$

The noise floor of the LTC2206-14 ADC in the Perseus is 77 dBFS, which is 8.6 dB worse than the theoretical maximum value.  $f_S = 80$  MHz for the Perseus. An NPR test with  $B_{RF} = f_S/2 = 40$  MHz,  $B_{IF} = 2.4$  kHz (SSB mode) and the 5340 kHz bandstop filter yielded NPR = **64.75 dB**. This is 9.26 dB worse than the theoretical value, and is attributable to the ADC's finite noise floor. This difference is comparable to the 8.6 dB difference in noise floor between the theoretical and "real-world" values.

Let us now derive the **process gain  $G_P$**  due to the presence of the band-limiting filter during the original NPR test:

$$G_P = 10 \log_{10}(f_S / 2 * B_{RF}) = 10 \log_{10}(80 / 2 * 5.537) = \mathbf{8.6 \text{ dB}} \quad (5)$$

We can now predict NPR for the first test case in Table 2 above:

$$\text{NPR} = (\text{NPR for } B_{RF} = f_S/2) + G_P = 64.75 + 8.6 = \mathbf{73.35 \text{ dB}} \quad (6)$$

The measured NPR was **72 dB**, well within the margin of error.

## K. General discussion of results:

In a conventional receiver, the effect of the high noise power outside the notch is twofold and most likely impacts the first and second mixers more than any of the downstream sections of the receiver. Firstly, the incident noise mixes with the noise pedestal of the LO to cause reciprocal mixing, which shows up as increased noise in the IF passband (ICN). Secondly, the noise components mix with each other, the LO, any LO spurs and the LO phase noise to produce a very large number of IMD products - much closer to the effect of a heavily-occupied band than a 2-signal test. Some of these IMD products will fall into the IF passband, further degrading ICN.

Secondary effects due to passive IMD in RF filter components, semiconductor filter switches, roofing filters etc. under the high noise loading will cause a further slight degradation in NPR.

In the IC-7700, the  $\approx 10$  dB NPR improvement with the 6 or 3 kHz roofing filters suggests that the second mixer is a significant contributor of IMD and/or reciprocal mixing noise when subjected to the higher noise loading with the 15 kHz roofing filter selected.

In K3 #2, NPR is 2 dB worse with Preamp off than the corresponding value for K3 #1. This may be due to slightly higher passive IMD in the 8-pole filter as compared to the 5-pole filter in K3 #1.

In the Perseus SDR, the best-case NPR was measured with preselector on, preamp off and dithering off. This suggests that the preselector is preventing the noise loading from driving the ADC input circuit into its non-linear region at levels approaching 0 dBFS.

If we apply the notched noise load to a perfect (ideal) DUT, the notch depth at the DUT output will be the same as that shown in **Fig.5** below. Any noise generated in the DUT will fill the notch with added noise, reducing its measured depth. Thus, the actual measured NPR is a measure of the amount of degradation due to reciprocal mixing and IMD noise generated by the notched noise load.

From **Fig.5** below, the notch depth at a bandwidth of 3.3 kHz is  $\approx 97$  dB. Thus, the NPR of an ideal receiver with  $<3.3$  kHz Hz IF bandwidth would also be  $\approx 97$  dB. By this yardstick, a 70 - 80 dB measured NPR appears quite respectable. It will be interesting to correlate the results of the NPR test with those of the more familiar 2-signal IMD3 dynamic range measurement.



Originally published: 9 September 2011. Update history:

- 8 June 2012 (Notes on theoretical max NPR of ADC added.)
- 2 September 2012 (TS-590S and FT-950 data added to Table 1.)
- 14 October 2012 (NPR test results for Yaesu FT-817 added to Table 1a.)
- 3 November 2012 (NPR test results for Elecraft KX3 added to Table 2.)
- 22 November 2012 (Refs. 10, 11 & 12 added.)
- 11 January 2013 (NPR test results for Icom IC-7200 added to Table 1a.)
- 4 March 2013 (NPR test results for Yaesu FTDX-3000 added to Table 1a.)

**Fig.5: W&G 5340 kHz bandstop filter amplitude/frequency response.**

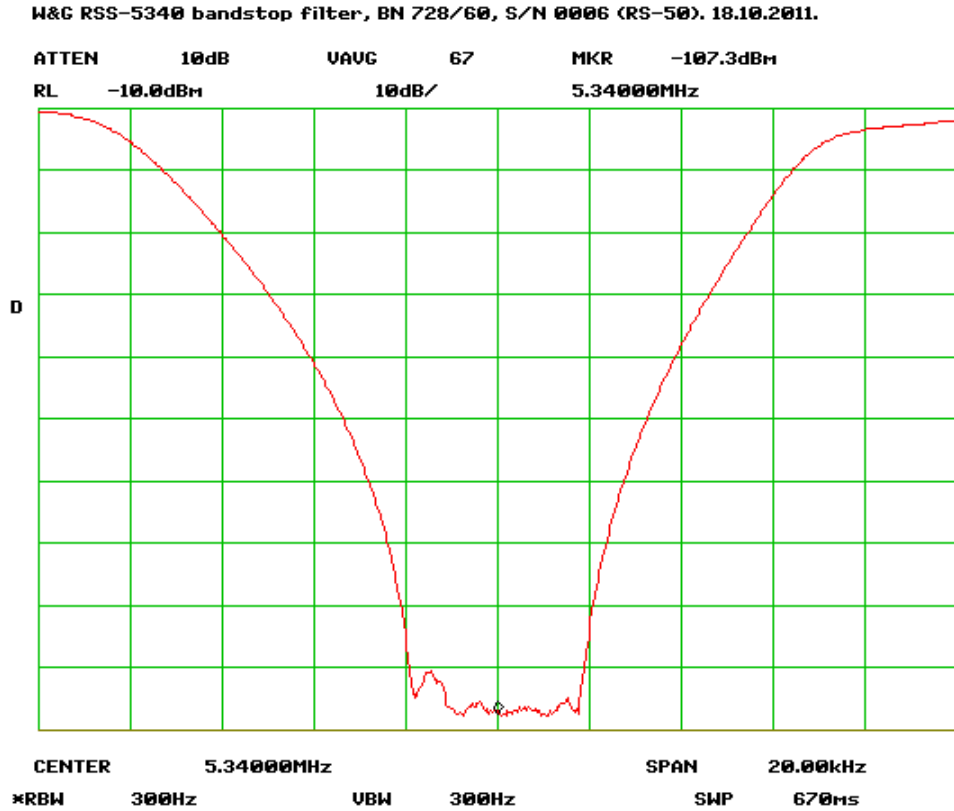

**Fig.6: The Wandel & Goltermann RS-50 White Noise Generator.**

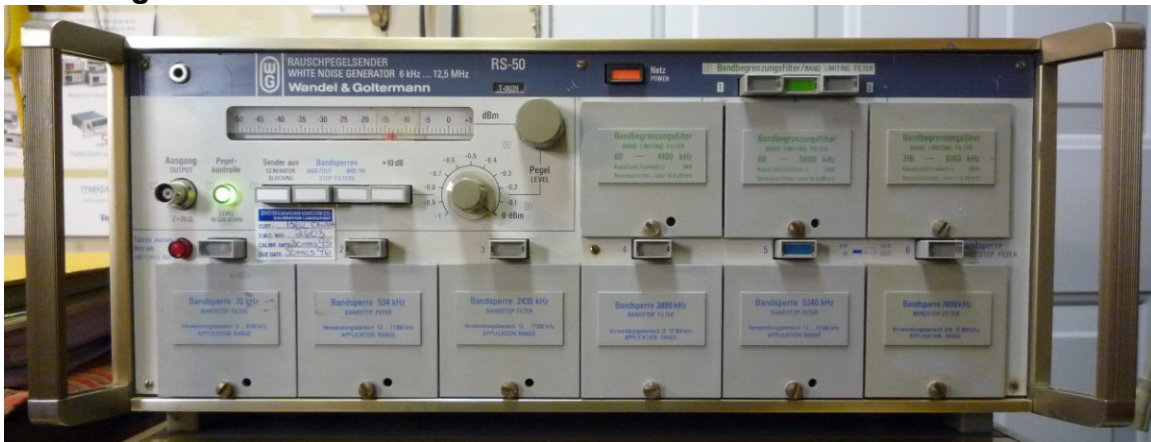

## L. References:

1. "Oscillator Noise Evaluation with a Crystal Notch Filter" by Wes Hayward W7ZOI, *QEX*, July/August 2008.
2. "Compare Receivers", *Microwaves & RF*, January 1987, pp. 104 – 108.
3. Marconi Instruments OA 2090 White Noise Test Set Operation & Maintenance Manual, 1971.
4. "[Measurement of all intermodulation products on HF receivers, with 24000 CW tones](#)", by Gianfranco Verbana I2VGO, 11<sup>th</sup> RENON Convention, Costalovara (Italy), 26-27 September 2009. [Mirror](#)
5. "Multichannel Communication Systems and White Noise Testing", by M.J. Tant, Marconi Instruments Ltd., July 1974.
6. "An Introduction to White Noise Testing of HF Receivers", by J.N. Dingley (Racal), IERE Conference on Radio Receivers and Associated Systems, No. 24, July 1972.
7. "Noise Power Ratio Measurement Tutorial", by Allen Katz and Robert Gray, Linearizer Technology Inc.
8. Noise Power Ratio (NPR) - A 65-Year Old Telephone System Specification Finds New Life in Modern Wireless Applications, by Walt Kester. Analog Devices Inc. Tutorial [MT-005](#), 2009.
9. "The Noise Power Ratio—Theory and ADC Testing," by Fred H. Irons, IEEE Transactions on Instrumentation and Measurement, Vol. 49, No. 3, June 2000, pp. 659-665.
10. "Improved Methods for Measuring Distortion in Broadband Devices", Application Note [5989-9880EN](#), December 2008, Agilent Technologies Inc.
11. "Noise Power Ratio (NPR) Testing of HF Receivers", by Adam M. Farson VA7OJ/AB4OJ. RSGB *RadCom*, December 2012, pp. 42-45.
12. "[Noise Power Ratio Testing](#)", presentation by author to North Shore Amateur Radio Club, North Vancouver BC, 22 November 2012.

**Acknowledgements:** The author is indebted to Gianfranco Verbana I2VGO for sharing his research and providing the theoretical basis for the test procedure described above, to Henry Rech for his encouragement in embarking upon this project and to Walter Salden VE7WRS for his invaluable assistance in building and characterising the crystal notch filters used at an earlier stage of the project.

*Copyright © 2009-2012 A. Farson VA7OJ/AB4OJ. All rights reserved.*